

# FITTING INSTRUCTIONS

## 535080 SPARE WHEEL MOUNT

Your TROJAN Spare Wheel Mount has been designed to mount onto the majority of Trailer drawbars (see sketch below) and to accept a wide variety of both 4 stud and 5 stud wheel rims. A padlock is provided to secure the spare wheel until it is required.

To mount the unit follow these instructions:

1. Select a suitable position on the trailer drawbar where the spare wheel will not interfere or foul with any other equipment i.e. Jockey Wheels, Winches, Gas Bottles etc.
2. Place the "U" bolt around the drawbar opposite where the mount is to be located and insert through the curved slots in the mount bracket. Loosely install the nuts and spring washers with the flat washer against the slot.
3. Rotate the "U" Bolt until it contacts both the top and bottom of the draw bar, and tighten the nuts to 77 Nm.
4. Insert a coach bolt through the rear of the square hole in the triangular plate and retain it in place by working the "starlock" washer over the threads. The second coach bolt then can be placed into the square slotted hole and held in the same manner.
5. Adjust the position of the coach bolt in the slotted hole to suit the spacing of the wheel stud pattern. Place the wheel over the coach bolts, install nuts and tighten to 77 Nm.
6. Insert the clevis pin through whichever of the remaining elongated holes lines up with a hole in the wheel and secure with the padlock.
7. Remember to put one of the padlock keys onto your key ring. You never know when you will need it. Store the spare keys in a safe place.

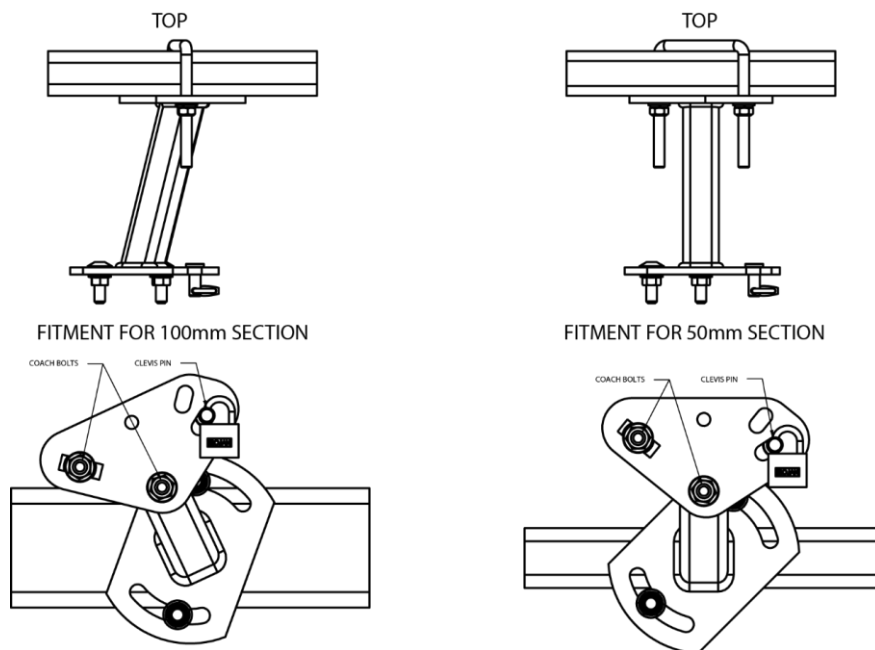

THE "U" BOLT ANGLE MAY BE ALTERED FOR DIFFERENT SIZED DRAWBARS

LOAD RATING: 30 kg

REVISION: B

PAGE 1 OF 1

DATE: 19/04/2021